



Arrow Engineering can manufacture welded steel (A36) tombstones for your fixturing needs. Please fax the following worksheet to Arrow for a quotation:

# of Sides: \_\_\_\_\_ Machine Model # to be used on: \_\_\_\_\_

T= \_\_\_\_\_ B= \_\_\_\_\_ B2= \_\_\_\_\_ L= \_\_\_\_\_ W= \_\_\_\_\_ H= \_\_\_\_\_

Bmax=630mm; B2max=630mm; Hmax=30in - T

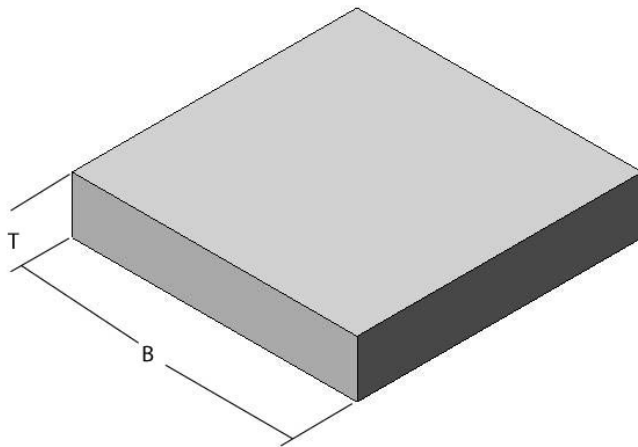

0 sides

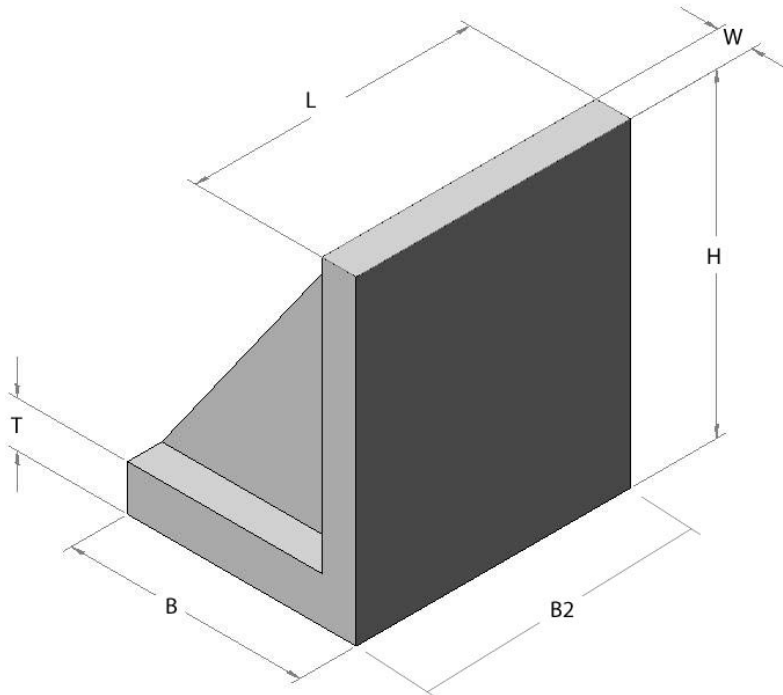

1 Side

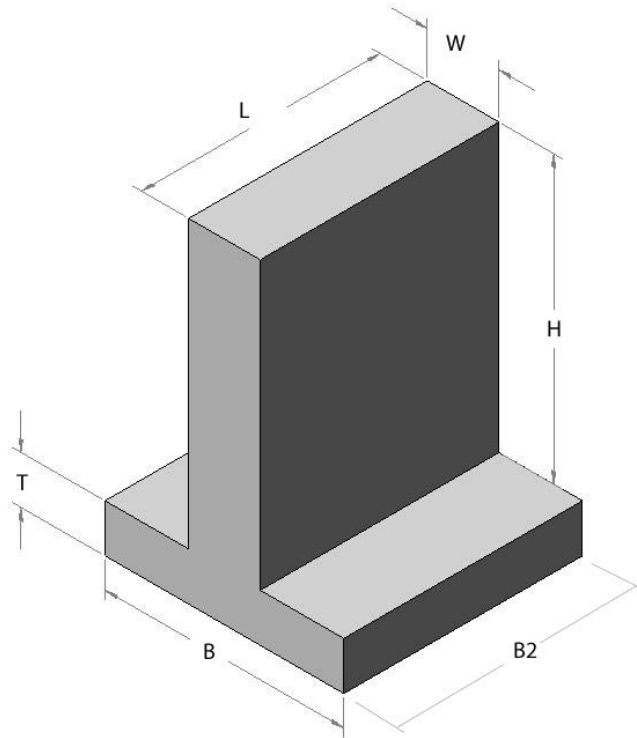

**2 Sides**

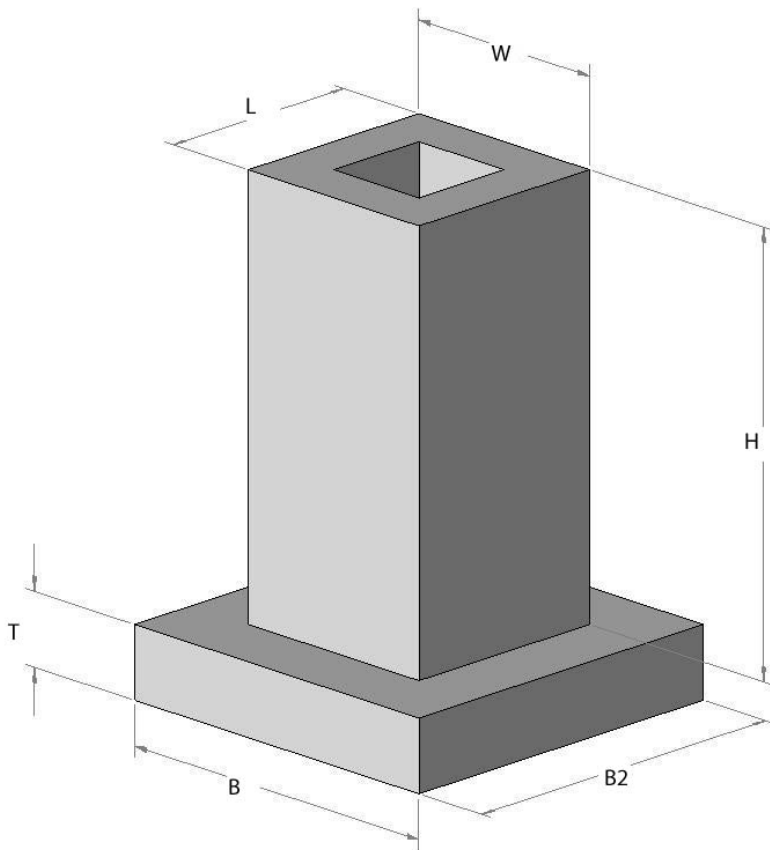

**4 Sides**



**Notes:**

- 1. Arrow welded tombstones are manufactured with the following standard tolerances.**

**Flatness: .001/12**  
**Parallelism: .001/12**  
**Perpendicularity: .001/12**  
**Surface Finish: 63RMS**

**Other tolerances will be quoted upon request.**

- 2. Arrow welded tombstones are ideal for manifold oil feed designs however weld location must be considered when gundrilling. Please note this on the worksheet so the Arrow Engineer's can ask appropriate questions or provide guidance for your application needs. If you wish Arrow to gundrill the tombstone a print must be provided for quotation.**
- 3. Arrow can pre-drill your tombstone for attachment of the *base only*, any *custom pattern*, or a predefined *grid*.**